



# HUBER

## Drum Screen LIQUID

Reliable fine screening with maximum separation efficiency

- ▶ Maximum retention of fibres and hair
- ▶ Operating reliability for membrane bioreactors
- ▶ Maximum COD / BOD<sub>5</sub> reduction rates

More information,  
downloads and  
current news





## Design and function

The characteristic feature of the HUBER Drum Screen LIQUID is its screen basket which is horizontally installed in the channel or in a tank. The wastewater to be treated flows through the basket from inside to outside. Whilst the wastewater flows through the open front into the screen basket, solids are retained within the drum. A special sealing between the channel and the front-end screen basket opening prevents unscreened wastewater from passing through the screen basket. The solids settling on the drum surface lead to gradual blinding of the surface. As a result, the water level upstream of the screen rises. Screen basket cleaning starts as soon as a specified maximum water level has been reached. The screen basket slowly rotates around its axis for cleaning. At its crown a spray nozzle bar sprays water onto the drum surface from the outside.

The solids adhering to the inside of the screen basket are dissolved and directed into a hopper arranged inside the drum. The screenings are discharged from the hopper by gravity. The screenings can optionally be pumped to a higher level.

The HUBER Wash Press WAP® liquid (see separate brochure) is available for further treatment of the separated screenings. The wash press dewateres the screenings prior to discharging them into a container.

## Technical data

- ▶ 3 sizes with 8 different lengths
- ▶ Drum diameter from 1.3 – 2.2 m
- ▶ Drum length up to 4 m
- ▶ Perforated plate from 1.5 – 3 mm
- ▶ STAR design perforations of 1 – 2 mm
- ▶ Mesh sizes from 0.2 – 0.75 mm
- ▶ Bar spacings from 0.5 – 3 mm
- ▶ For channel or tank installation



*CarbonWin® process illustration: The better preliminary clarifier tank for optimum reduction rates (see individual brochure).*

## A tailored solution to suit any application

- ▶ Industrial and municipal applications
- ▶ Primary and secondary treatment stage
- ▶ Protection of membrane plants
- ▶ Replacement for primary settlement tank
- ▶ Load reduction in the biological treatment system through reduction of COD / BOD / AFS
- ▶ Screening in the inlet to power plants
- ▶ Treatment of cooling water circuits
- ▶ Brewery wastewater
- ▶ River and sea outfall
- ▶ Surface and river water screening

## Obvious benefits

- ▶ High throughput capacity – maximum separation efficiency
- ▶ Easy maintenance
- ▶ Low operation costs
- ▶ Low life-cycle costs
- ▶ Optional high pressure cleaning reduces maintenance requirements
- ▶ Various possible applications
- ▶ Maximum corrosion protection through stainless steel design and acid treatment in a pickling bath

## High-pressure cleaning

For preventive basket cleaning an innovative automatic high pressure system can be integrated as an option. The nozzle head, which rotates automatically as a result of the water pressure, is guided in a linear movement throughout the entire length of the screen basket. This ensures very thorough and, at the same time, efficient cleaning of the entire screen basket. Water demand and operator attendance are reduced to a minimum.

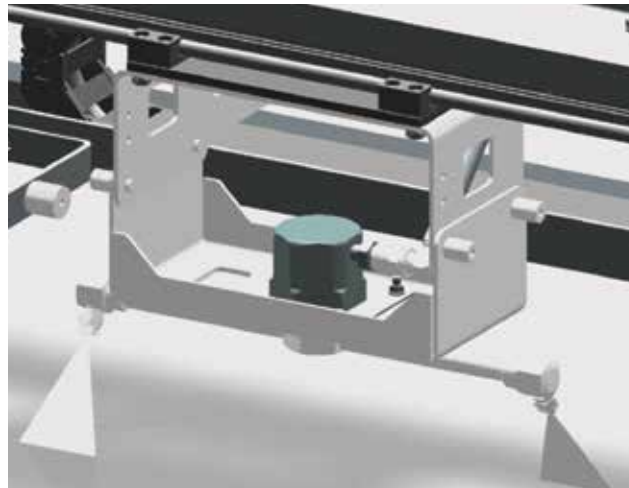

*Automatic high pressure cleaning system of the HUBER Drum Screen LIQUID.*

## Reliable sealing

Every system is only as good as its sealing system in the inlet of the machine. A special PU seal has been integrated to ensure reliable solids separation. The PU seal ensures that no unscreened wastewater can pass through the HUBER Drum Screen LIQUID. This means that the best separation performance can be reliably and permanently maintained.



*Polyurethane sealing in the inlet of the HUBER Drum Screen LIQUID.*

## Low-maintenance direct drive

The HUBER Drum Screen LIQUID is equipped with a unique, self-adjusting bearing unit. The drum can therefore be mounted stress-free with automatic angle compensation.

The bearings are automatically lubricated for maximum availability.



*Low-maintenance chain drive on the HUBER Drum Screen LIQUID.*

## Drum Screen LIQUID ww

HUBER Drum Screen LIQUID with wedge wire drum, wedge wire sizes 0.5 / 1 / 2 / 3 mm.

Solids retention with high throughput capacities of up to 10,000 m<sup>3</sup>/h per machine.

### Typical applications:

Mechanical pre-treatment for sewage treatment plants, industrial solid-liquid separation.

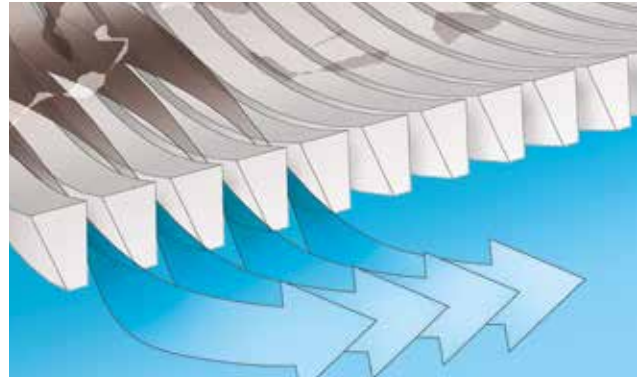

Wedge wire for high hydraulic throughputs.

## Drum Screen LIQUID pp

HUBER Drum Screen LIQUID with mesh, optionally with 1.5 / 2 / 3 mm perforation.

High separation efficiency and retention of fibres and hair.

### Typical applications for 1 and 2 mm perforation:

Protection of hollow-fibre membrane filtration plants

Typical applications 3 mm perforation:

Protection of plate membrane filtration plants

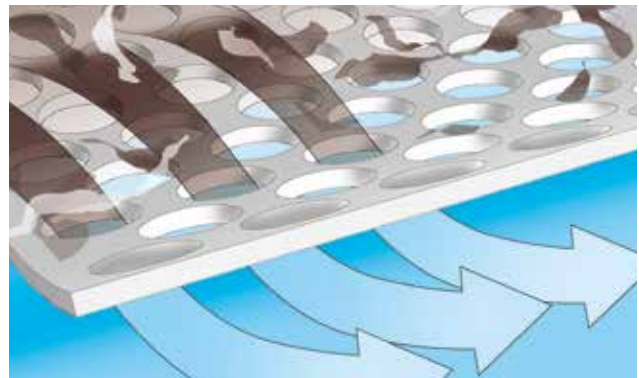

Perforated plate for high separation efficiency and at the same time high hydraulic capacity.

## Drum Screen LIQUID Star

HUBER Drum Screen LIQUID with tilted mesh, optionally with 1 / 1.5 / 2 mm perforation.

Increased screen surface for higher throughputs.  
High separation efficiency and retention of fibres and hair.

### Typical applications:

Protection of membrane filtration plants

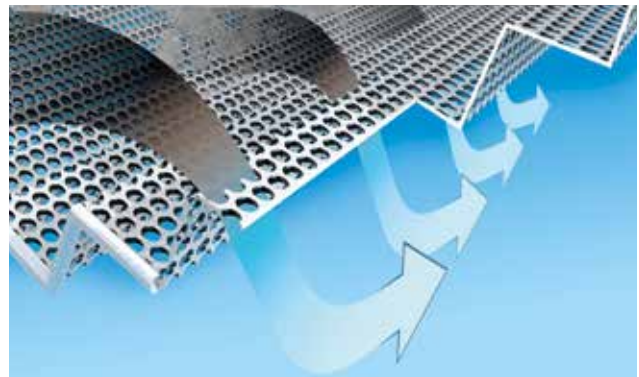

Folded perforated plate STAR with increased screen surface.

## Drum Screen LIQUID Mesh

HUBER Drum Screen LIQUID with mesh, mesh sizes from 0.2 up to 0.75 mm.

Maximum separation efficiency and reduction of COD and BOD by up to 40 %.

### Typical applications:

Load reduction in the preliminary treatment stage

Replacement for primary settlement tank

Sea and river outfall applications

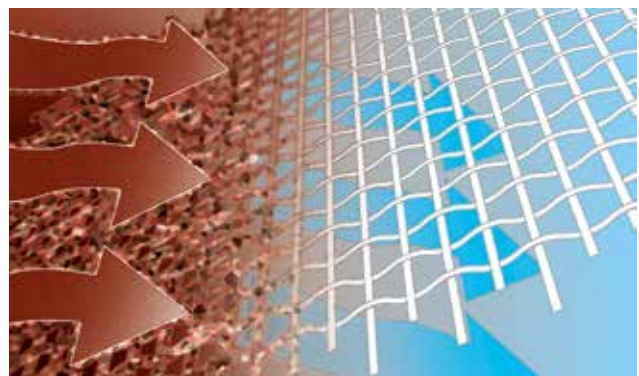

Mesh for maximum separation requirements.

## Application example: Load reduction in bio-system

Thanks to its excellent separation efficiency, the HUBER Drum Screen LIQUID mesh is very well suited to be used to reduce the solids loads in the biological treatment stage. A HUBER Drum Screen LIQUID mesh with 0.3 mm mesh size for example achieves reduction rates of up to 60 % for filterable solids (AFS) and up to 40 % for chemical oxygen demand (COD). Peak loads can thus be balanced, aeration energy in the aerobic treatment stage can be saved and the capacity of the sewage treatment plant increased. Moreover, the screenings separated by the HUBER Drum Screen LIQUID can be passed to the digester to increase biogas production.

Another application of the HUBER Drum Screen LIQUID mesh is its installation as replacement of the primary settlement tank. Due to its low space requirements and low hydraulic loss, the HUBER Drum Screen LIQUID is also very well suited to be used to upgrade and modernise existing sewage treatment plants.



*HUBER Drum Screen LIQUID for maximum separation efficiency and at the same time low pressure losses.*



*Screenings separated by the HUBER Drum Screen LIQUID Mesh: The load to be handled in the biological treatment stage is reduced and more gas can be produced in the digester.*

### HUBER SE

Industriepark Erasbach A1 | 92334 Berching  
Phone: +49 8462 201-0 | info@huber.de

[www.huber.de](http://www.huber.de)

HUBER Drum Screen LIQUID

Subject to technical modification | 0.1 / 3 – 2.2024 – 5.2016