



HUBER Screenings Wash Press WAP® SL HP

Screenings Wash Press for washout of organics and controlled high-pressure dewatering

- ▶ Dewatering performance up to 60 % DR
- ▶ High washout factor
- ▶ Increase of the thermal value of screenings

Mehr Infos,
Downloads und
aktuelle News



Design and function

High washout factor due to intensive washing

The ROTAMAT® Screenings Wash Press SL HP operates in a batch mode. Screenings either drop into the launder tank directly from a screen or conveyor, or they are flushed into the tank through a launder channel. After a batch of screenings has been fed, the tank is filled up with wash water and agitated for an adjustable period by means of an impeller. The faecal matter is loosened and removed from the screenings by high turbulence and shear. The washing intensity is selectable and can be adjusted to suit the specific screenings quality.

After the washing cycle has been finished, an automatic valve opens and the wash water drains through perforations in the trough. It returns, together with the faecal matter, to the wastewater flow.

Reduced disposal costs with high pressure

The washed screenings are further conveyed into the press zone where they are dewatered by means of a sturdy compacting screw. In the following automatically controlled second press zone the screenings are constantly compacted and dewatered under high pressure to a DS content of up to 60 %. Especially wearresistant and solid materials in the conical high-pressure unit ensure reliable long-term operation of the plant. The press water from the screenings compaction is collected under the high-pressure unit and discharged along with the wash water which is rich in carbon. Automatic cleaning with water of the press and wash water collecting tank under the machine and the complete highpressure unit is possible. The washed and compacted screenings are finally transported through the conical discharge pipe into a skip.

For an optimised maintenance strategy, the machines are equipped with wear detection of the compacting screw in the press zone. The system automatically detects the ideal time for maintenance of the auger.



Maximum washing and dewatering results with the HUBER Screenings Wash Press WAP® SL HP.

Benefits

- ▶ High-intensity washing in launder tank
- ▶ Quality factor of washed screenings: < 20 mg BOD₅ / g DR
- ▶ Dewatering performance of up to 60 % DR
- ▶ Volume, weight and disposal cost reduction of up to 85 %
- ▶ Hydraulically controlled high-pressure zone
- ▶ Return of carbon-rich filtrate to the wastewater
- ▶ Screened wastewater or process water can be used as wash water
- ▶ Completely made of stainless steel (including the compacting screw)
- ▶ Compacting screw with reinforced flights for wear protection
- ▶ High economic efficiency due to reduced transport and disposal costs
- ▶ Automatic wear detection of the compacting screw

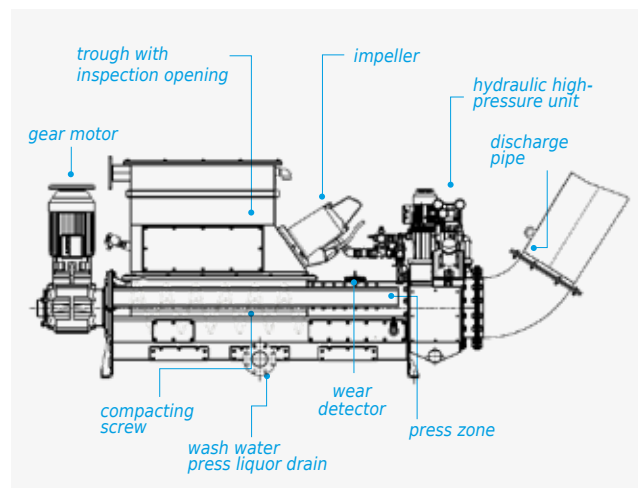

The hydraulic high-pressure unit at the end of the wash press guarantees a maximum DR.

HUBER SE

Industriepark Erasbach A1 | 92334 Berching
Phone: +49 8462201-0 | info@huber.de
www.huber.de

HUBER Screenings Wash Press WAP® SL HP
Subject to technical modification | 0,1 / 5 – 10.2023 – 4.2005