



# HUBER

## Bogenpress B-PRESS

- ▶ Belt filter press for municipal and industrial sludge
- ▶ High-performance belt filter press for best dewatering results
- ▶ Combi-unit: thickening and dewatering in one working process

More information,  
downloads and  
current news



## The Machines – Their Advantages

### The new HUBER Bogenpress B-PRESS

A new, extended high-performance pre-dewatering zone with chicanes, the bow zone, plus two perforated dewatering rolls ensure optimal pre-treatment and compaction of the flocculated sludge so that it can be exposed to maximum pressure in the following high pressure zone which is equipped with press rolls decreasing in diameter (4, 6, 8, or 10 rolls). This process guarantees highest dewatering results. The machine is equipped with detachable covers to provide easy access to moving machine parts.

### HUBER Bogenpress B-PRESS BS Combi

The BS Combi version has a belt thickener (HUBER Belt Thickener DrainBelt) mounted on the actual Bogenpress. The sludge is at first pre-thickened on the belt thickener prior to passing through the dewatering zones of the Bogenpress. The combination system is able to handle up to 80 m<sup>3</sup>/h. Another advantage of the system is that coagulant agent addition is required only once for both the thickening and dewatering process.

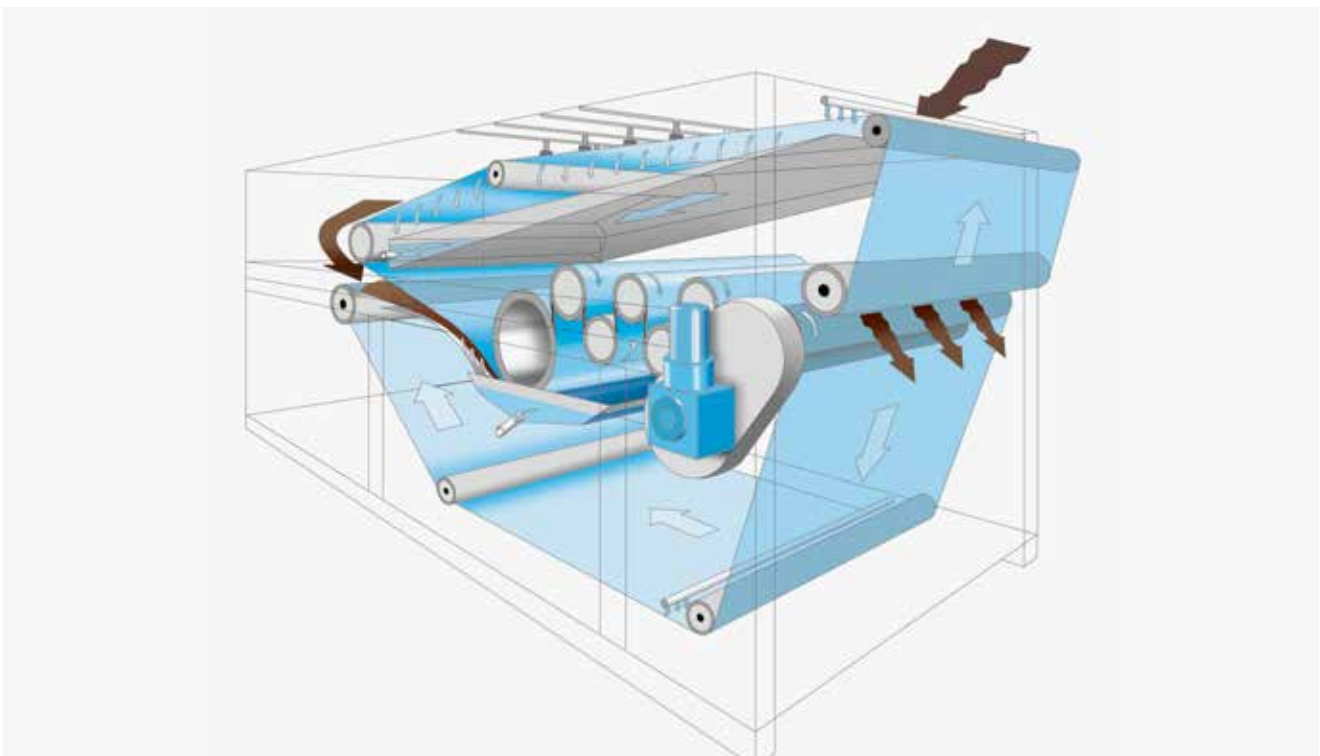

*HUBER Bogenpress B-PRESS with 8 rolls.*

## HUBER SE

Industriepark Erasbach A1 | 92334 Berching  
Phone: +49 8462 201-0 | info@huber.de  
[www.huber.de](http://www.huber.de)

HUBER Bogenpress B-PRESS

Subject to technical modification | 0,1 / 5 – 4.2022 – 11.2003