

Guard grate ASG for manhole covers, load bearing up to 150 kg



The figure shown here may contain special accessories.

Guard grate in accordance with DGUV regulation 103-007, rectangular, made from 1.4307 (AISI 304 L) stainless steel, universally applicable and retrofittable under manhole covers.

Grate made of perforated plate with 5 mm perforations in staggered rows, load bearing capacity 150 kg, hinged and lockable, provided for locking with a customer provided padlock.

Support, made of angle profile, for internal bolted fixing under the manhole cover.

Guard grate for mounting under the manhole cover and above the climbing system.

Both grate and support are shielded arc-welded and acid bath cleaned before washing, drying and surface passivation.

Fixing material included.

Options:

- ▶ 1.4404 (AISI 316 L) stainless steel
- ▶ Lockable version
- ▶ Removable grate for round manholes
- ▶ Non-standard sizes



In stock SD1

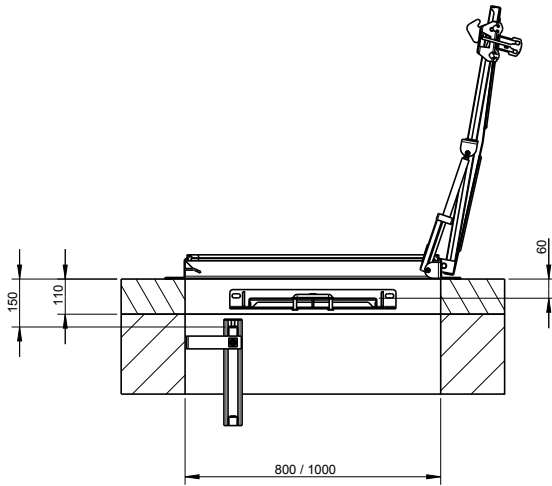

In stock SD7

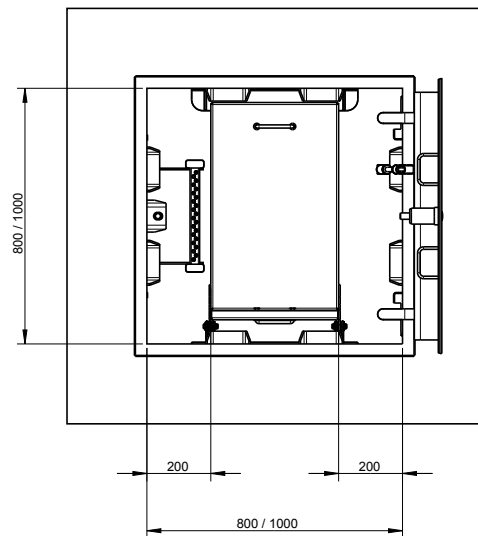
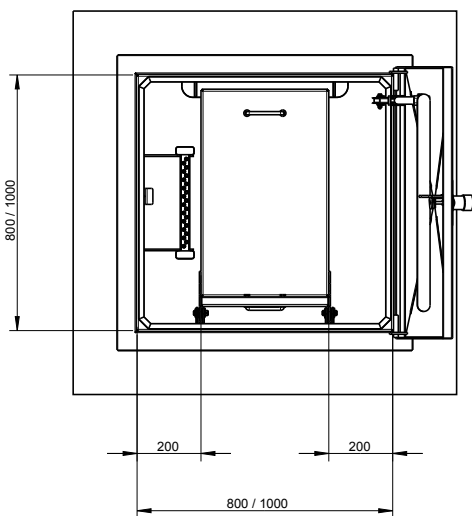
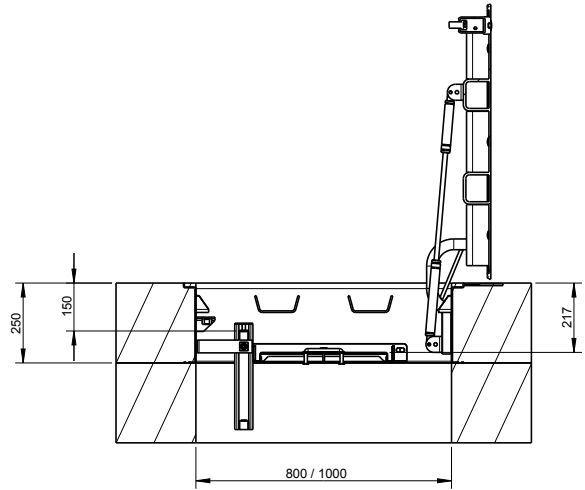

Model	Size a x b	Order no.
Standard Model	800 x 800	ASG 800x800 W400
Standard Model	1000 x 1000	ASG 1000x1000 W600

Ask for further dimensions. All measurements in mm.



Guard grate ASG for manhole covers, load bearing up to 150 kg
 Subject to technical modification | Drawing no. 50973614, 2.2023

HUBER SE | Industriepark Erasbach A1 | D-92334 Berching | Telefon: +49 8462 201-0 | info@huber.de | www.huber.de