

Weatherproof manhole cover SD1.P, premium model, rectangular type



The figure shown here may contain special accessories.

Manhole cover, premium model, weatherproof, rectangular in shape, completely made of 1.4307 (AISI 304 L) stainless steel.

Based on DIN 1239:2018-4, suitable for use in Ex zone 1.

The cover is made of stainless steel plate, with a centrally raised profile, inner cross bracing for rigidity, self-retracting lock which can be opened with a special key, two stainless steel gas assisted spring dampers (short version, 650N), with integrated self-retracting arrestor which can only be undone by hand, guided by a non-detachable U-profile (the spring damper holder is full penetration welded on three sides), with stable concealed hinges for protection against vandalism, with a circumferential insect-proof rubber seal on the inside (frost-proof and weather-resistant), replaceable, clamped into a groove in the cover.

Insulation of the cover, polyurethane hard foam, CFC-free, with bottom protection plate made of stainless steel. A special method is applied to inject the hard foam in liquid form into the cover to ensure the space is filled completely without any gaps. With handle as help for opening mounted in the middle of the cover. With angles welded on to subsequently receive a customer-supplied magnetic contact (including fixing screws).

A connection for potential equalisation is provided.

Frame consisting of 90 mm angle section, flanged on both sides, with four vertically welded on clips provided for bolted fixing inside the shaft as lift lock (one dowelling clip on each side), with three boreholes for bolted fixing on each frame side. With two additional frame fixings in the section of the two gas-assisted spring dampers.

Manhole cover and frame shielded arc-welded, acid-treated in a pickling bath and passivated.

This pickling method ensures that all cavities are reached and optimal corrosion protection is guaranteed.

Fixing material, gasket strip and operating key included.

Options:

- ▶ 1.4404 (AISI 316 L) stainless steel
- ▶ Air vent DN 150
- ▶ Safety lock for increased security, with or without profile cylinder
- ▶ Non-standard sizes
- ▶ Possibility to open the cover from below
- ▶ Pollen filter or biofilter (for odour elimination), or wind ventilator within the air vent
- ▶ Lacquer according to RAL colour chart
- ▶ Safety guard / barrier
- ▶ Safety guard / antifall guard



Weatherproof manhole cover SD1.P, premium model, rectangular type

Subject to technical modification | Drawing no. 50716664, 5.2022

HUBER SE | Industriepark Erasbach A1 | D-92334 Berching | Telefon: +49 8462 201-0 | info@huber.de | www.huber.de

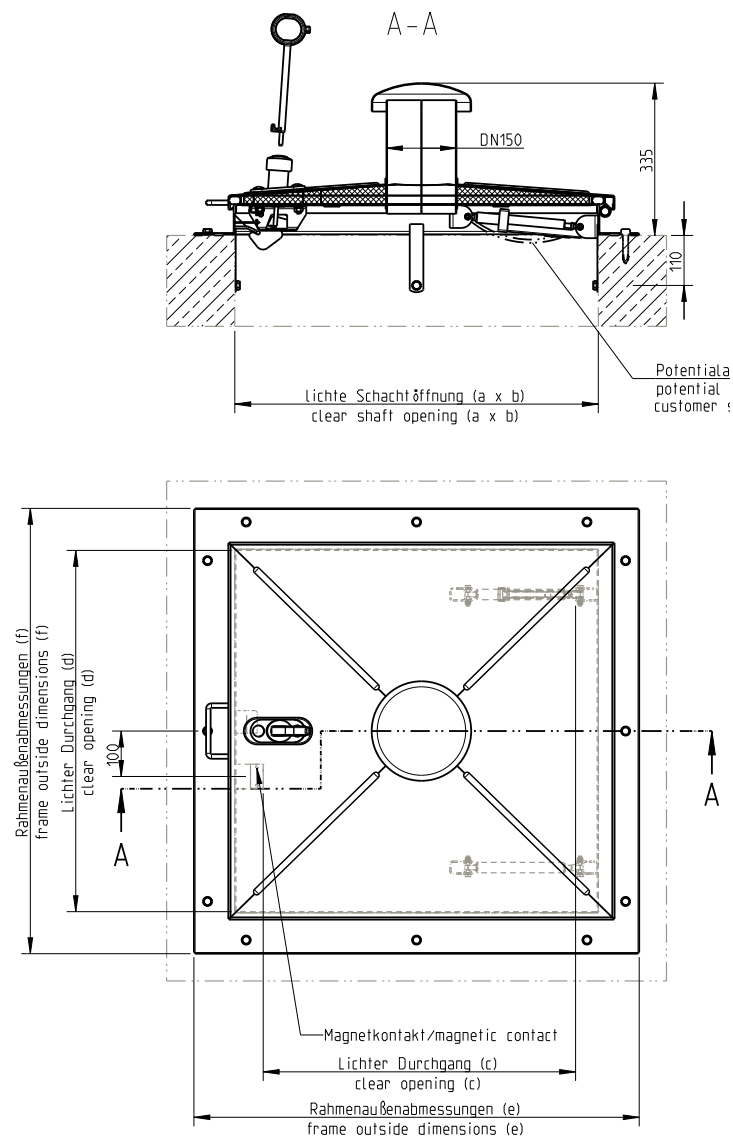

Model	Size a x b	Oder no.	Inside pass c x d	Frame outside dimensions e x f
With insulation of cover, without FCKW	800 x 800	188/I-P	686 x 795	980 x 980
With air vent DN 150 and insulation of cover, without FCKW	800 x 800	188/ID-P	686 x 795	980 x 980
With insulation of cover, without FCKW	1000 x 1000	111/I-P	886 x 995	1180 x 1180
With air vent DN 150 and insulation of cover, without FCKW	1000 x 1000	111/ID-P	886 x 995	1180 x 1180

Ask for further dimensions.



Weatherproof manhole cover SD1.P, premium model, rectangular type

Subject to technical modification | Drawing no. 50716664, 5.2022

HUBER SE | Industriepark Erasbach A1 | D-92334 Berching | Telefon: +49 8462 201-0 | info@huber.de | www.huber.de