

Sliding hatch cover SD12



The figure shown here may contain special accessories.

Sliding hatch cover, completely made of 1.4307 (AISI 304 L) stainless steel, with smooth finish.

The cover is made of a stable stainless steel plate and equipped with plastic rollers and maintenance-free journal bearings. The cover is installed in an external guide rail and cannot be removed. Locking when closed is possible by a cylindrical lock.

The rails consist of 60/40/2 mm rectangular section fixed with dowels along the rail edge.

Manhole cover and rails shielded arc-welded, acid-treated in a pickling bath and passivated.

Operating key included.

Dimensions according to individual requirements Available options:

- A) straight version
- B) circular version

The sliding cover provides access to downward leading stairs.

Options:

- ▶ 1.4404 (AISI 316 L) stainless steel
- ▶ Special design available on request



geschlossener Zustand / Closed

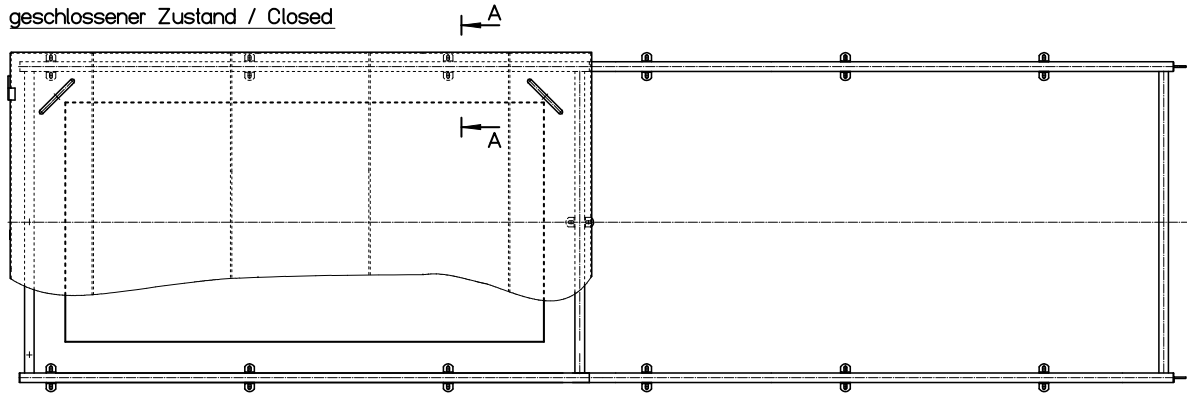

geöffneter Zustand / Open

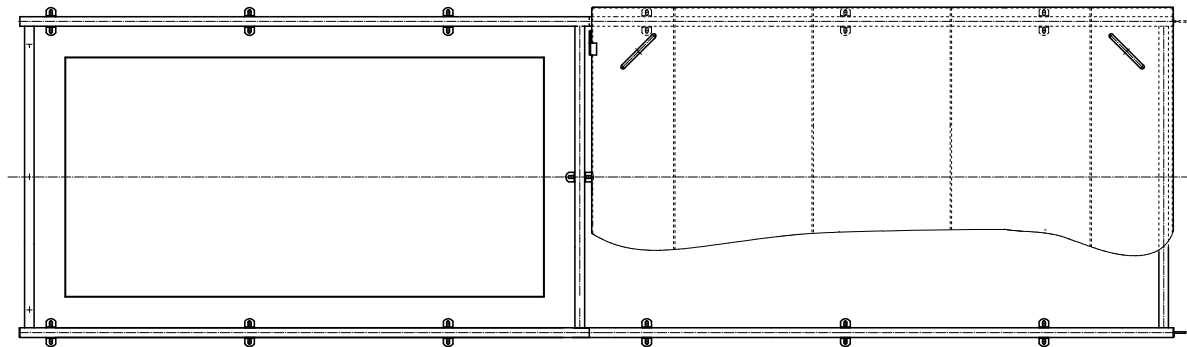

Schnitt: A-A
section: A-A

