

Round Pressure-Tight Door TT7.R with Screw Locks

Access door for containers, especially in the field of potable water supply, pressure-tight up to a water gauge of 10 m.



The figure shown here may contain special accessories.

Pressure-tight door, pressure-tight up to a water gauge of 10 m, opening to the pressure side, ready for installation, to be lined on both sides, round, completely made from 1.4404 (AISI 316 L) stainless steel, statically certified.

Door, bent for increased pressure capacity. With circumferential square silicone seal, suitable for potable water, ozone resistant, certified to KTW and DVGW W 270 standards. Locking with the help of screw locks operable only from the dry side. With stable maintenance-free hinge plates between the door and frame.

Frame, designed as an access duct cover with a centrally welded wall flange. Frame with lifting eyes.

Frame and door shielded arc-welded and acid bath cleaned before washing, drying and surface passivation.

Note:

Guarantee for tightness between the frame and concrete is only provided if the concrete structure is homogeneous all around the circumference. The minimum concrete quality and corresponding concrete classes are to be determined by the customer. In the case of frames for retrofitting, the manufacturer's specifications for the fixing material must be observed.

Ordering options:

Door opening options:

- ▶ Hinges on left
- ▶ Hinges on right

Options:

- ▶ Frame, for retrofitting, space required for the frame: 150 mm, circumferential. Prerequisite is a plane inner wall surface, tolerance: ± 1 mm per metre.
- ▶ Pressure door for round tanks (only possible for setting in concrete)
- ▶ Centrally installed inspection window, inside diameter: 150 mm, with or without window wiper

or

- ▶ Installed LED underwater spotlight
- ▶ Installed cylinder lock (operable from one side)
- ▶ Sanding of frame parts in contact with concrete
- ▶ Sampling valve on external door surface
- ▶ Provided for welding to the PE coating
- ▶ Potential equalisation on the frame
- ▶ Completely made of 1.4307 (AISI 304 L) stainless steel



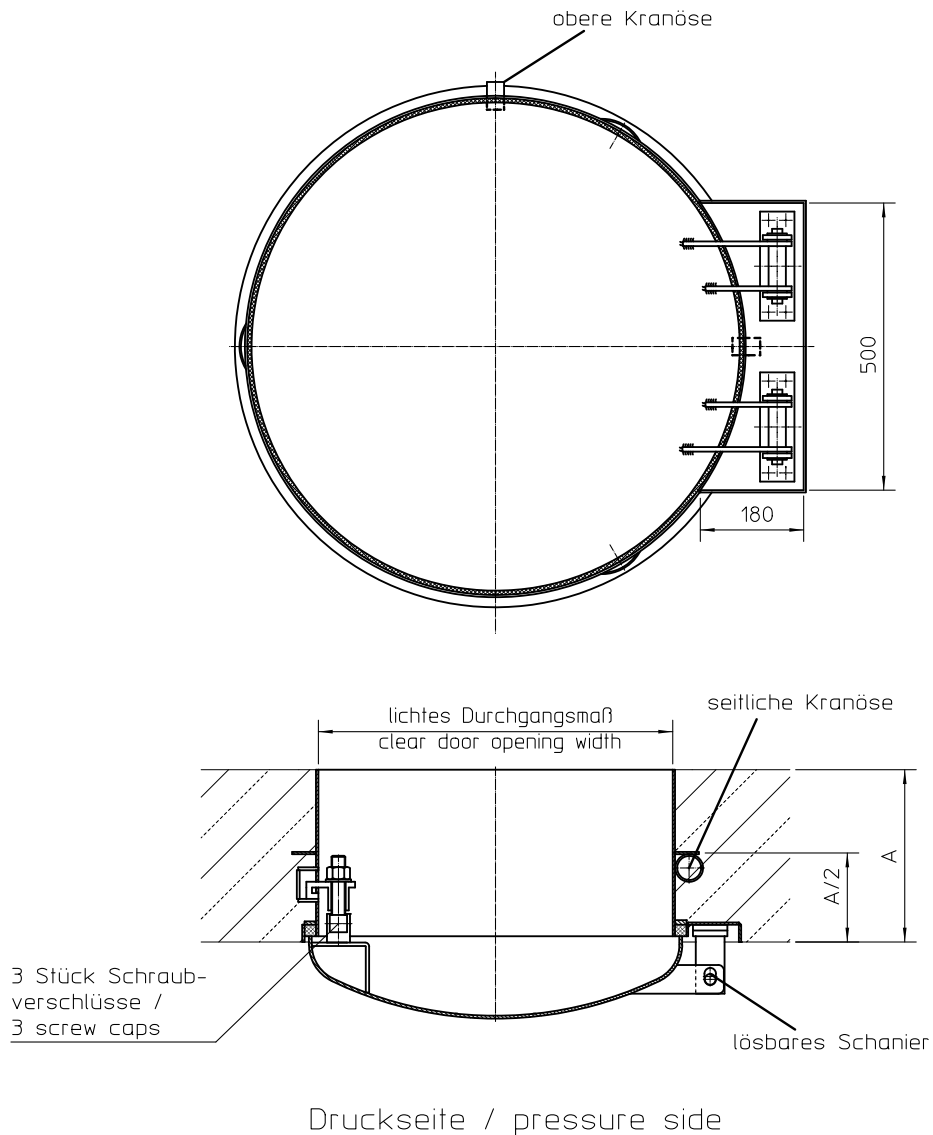

Nominal size order no.	Clear door opening \emptyset	Clear door opening \emptyset	For wall thickness A
600	617	710	
800	817	910	
1000	1017	1110	

Ask for further dimensions. All measurements in mm.



Round Pressure-Tight Door TT7.R with Screw Locks

Subject to technical modification | Drawing no. 190.170, 5.2022