

Round Inspection Cover TT8b

Sight glass in the bottom of water tanks, pressure-tight up to a water gauge of 10 m.



The figure shown here may contain special accessories.

Inspection cover, pressure-tight up to a water gauge of 10 m, round, completely made from 1.4404 (AISI 316 L) stainless steel, can be lined on both sides.

Sight glass with 15 mm thick safety glass, convex towards the pressure side. Sealing with two rubber seals. Clear sight diameter: 400 mm.

Access duct cover with centrally welded wall flange, provided for embedding in concrete. Wall flange dimensions: 616 mm.

Access duct cover shielded arc-welded, acid-treated in a pickling bath and passivated.

Options:

- ▶ 1.4307 (AISI 304 L) stainless steel
- ▶ Sanding of wall pipe parts in contact with concrete

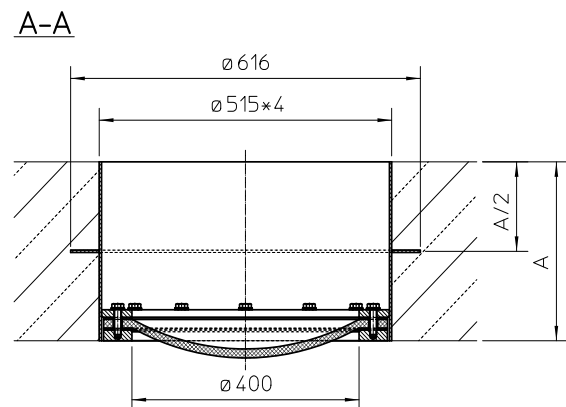
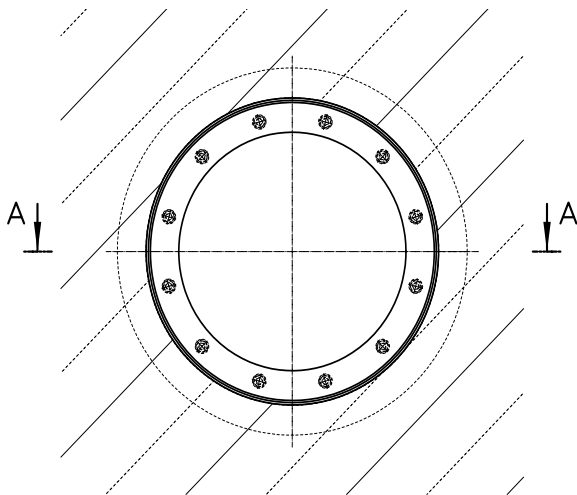

Druckseite / pressure side

Nominal size order no.	Clear opening \varnothing	Wall flange diameter \varnothing	For wall thickness A
0400 SL	400	616	

Ask for further dimensions. All measurements in mm.



Round Inspection Cover TT8b

Subject to technical modification | Drawing no. 190.171/2, 5.2022

HUBER SE | Industriepark Erasbach A1 | D-92334 Berching | Telefon: +49 8462 201-0 | info@huber.de | www.huber.de